

640/1 Typical Surface Mount Flange For Guards with Rear Legs

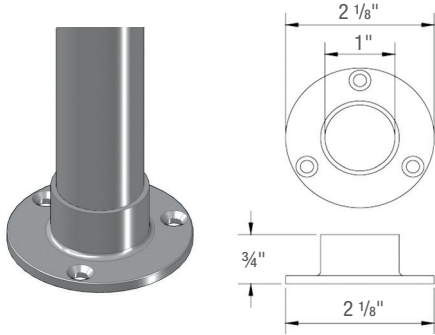

641/1 Typical Surface Mount Flange For Guards without Rear Legs

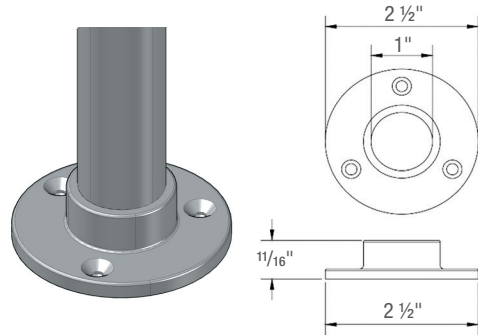

640B-2/1 Round Surface Mount Flange with Optional Flange Cover

Assembly with Welded Flange and Loose Cover

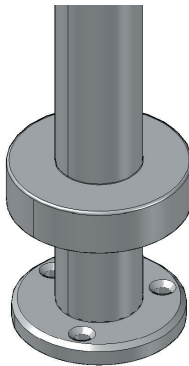

Mounting Flange

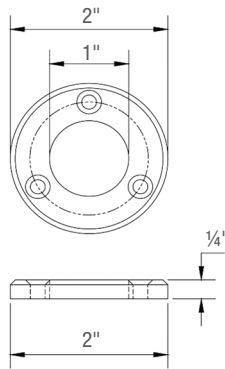

Optional Flange Cover

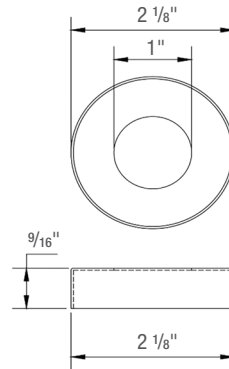

644B-3/1 Narrow Surface Mount Flange with Optional Flange Cover

Assembly with Welded Flange and Loose Cover

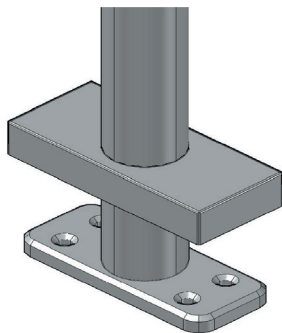

Mounting Flange

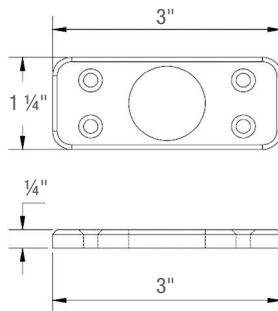

Optional Flange Cover

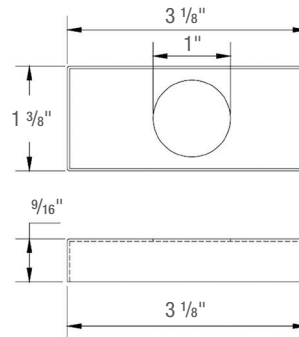

Specifications for reference only and may be changed without notice. All orders require approved shop drawings prior to release to production. Products are drawn and built to meet NSF Standard 2. It is the responsibility of the customer to ensure product meets local health board standards.



223

This Under Counter Mount System is a Compression Fitting with Threaded Sleeve and Nut/Washer System.

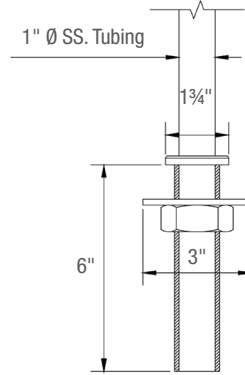

223/A

This Under Counter Mount System Includes a Grommet and Threaded Sleeve with Nut To Snug To Counter and Washer Which Screws To Wood Counter Substrate.

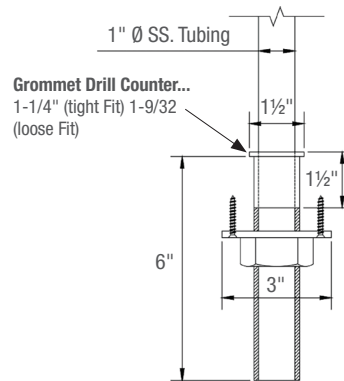

223/B

This Under Counter Mount System Includes a Grommet and Requires The Post To Be Welded To an Under Counter Mounting Plate Onsite By Others.

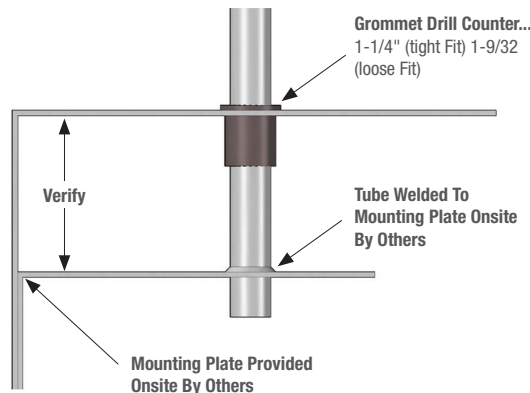

Specifications for reference only and may be changed without notice. All orders require approved shop drawings prior to release to production. Products are drawn and built to meet NSF Standard 2. It is the responsibility of the customer to ensure product meets local health board standards.

