

PREMIER HEATER SPECIFICATION — GENERAL

Premier strip heater fixtures are UL listed with mark prominently displayed. Typically, wires are provided chased through the customer specified upright tubes. The warmer unit is to be wired inside the stainless steel shroud via a junction box in the shroud. The wire chase is then wired to the supplied control enclosure which is mounted in a convenient location usual-ly behind the counter. This is simply a switch/control for the different elements in the warmer. The control enclosure is wired directly to the building supply power through a junction box or any enclosure that is UL listed. Units are typically supplied in a stainless steel shroud and a UL/NSF/ANSI finish is generally made to match the food guard posts.

STANDARD INSTALLATION ILLUSTRATION

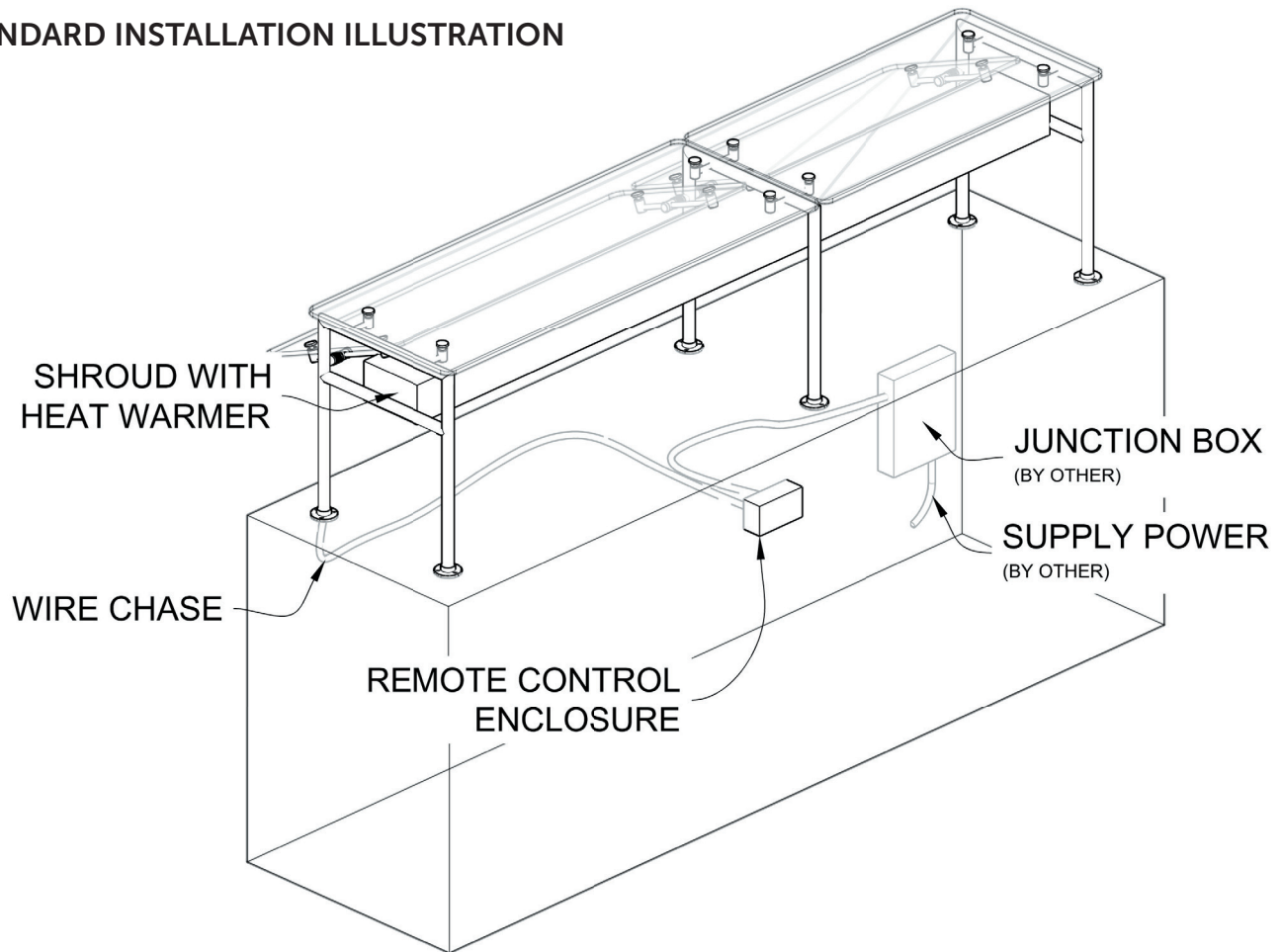

ADDITIONAL INFORMATION

All Premier warmers are built and supplied by Hatco. For more specific details regarding electrical specifications and wiring schematics, please refer to Hatco's document library on their website at <http://www.hatcocorp.com/document-library>.

Hatco Corporation
635 South 28th street
Milwaukee, WI 53215
(800) 558-0607

Specifications for reference only and may be changed without notice. All orders require approved shop drawings prior to release to production. Products are drawn and built to meet NSF Standard 2. It is the responsibility of the customer to ensure product meets local health board standards.

